

Surface Mount General Purpose Silicon Rectifier

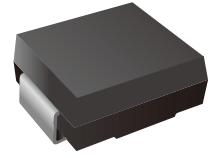

Features

- For surface mounted applications
- Low profile package
- Glass Passivated Chip Junction
- Easy to pick and place
- Lead free in comply with EU RoHS 2011/65/EU directives

Functional Diagram

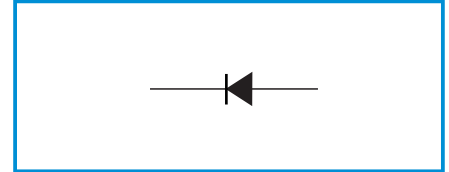

Mechanical Data

- Case: SMC
- Terminals: Solderable per MIL-STD-750, Method 2026
- Approx. Weight: 0.22g / 0.0077oz
- Polarity: Color band denotes cathode end
- Marking: S8K~S8M

Maximum Ratings and Electrical Characteristics

Ratings at 25 °C ambient temperature unless otherwise specified.

Single phase half-wave 60 Hz, resistive or inductive load, for capacitive load current derate by 20 %.

Parameter	Symbols	LTS8KC	LTS8MC	Units
Maximum Repetitive Peak Reverse Voltage	V_{RRM}	800	1000	V
Maximum RMS voltage	V_{RMS}	560	700	V
Maximum DC Blocking Voltage	V_{DC}	800	1000	V
Maximum Average Forward Rectified Current	$I_{F(AV)}$	8		A
Peak Forward Surge Current 8.3 ms Single Half Sine Wave Superimposed on Rated Load	I_{FSM}	200		A
Maximum Instantaneous Forward Voltage at 8 A	V_F	0.985		V
Maximum DC Reverse Current $T_a = 25\text{ }^\circ\text{C}$ at Rated DC Blocking Voltage $T_a = 125\text{ }^\circ\text{C}$	I_R	10 250		μA
Typical Junction Capacitance ⁽¹⁾	C_j	40		pF
Typical Thermal Resistance ⁽²⁾	$R_{\theta JA}$ $R_{\theta JC}$	35 13		$^\circ\text{C/W}$
Operating and Storage Temperature Range	T_j, T_{stg}	-55 ~ +150		$^\circ\text{C}$

(1) Measured at 1 MHz and applied reverse voltage of 4 V D.C

(2) P.C.B. mounted with 2.0" X 2.0" (5 X 5 cm) copper pad areas.

Electrical characteristics Curves

Fig.1 Forward Current Derating Curve

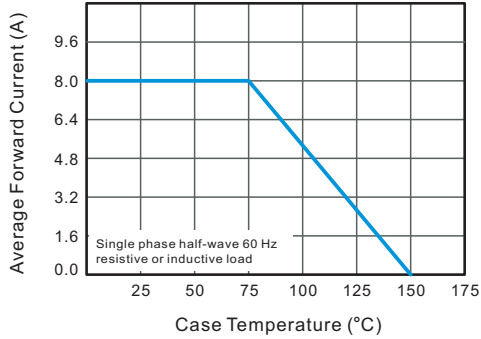

Fig.2 Typical Reverse Characteristics

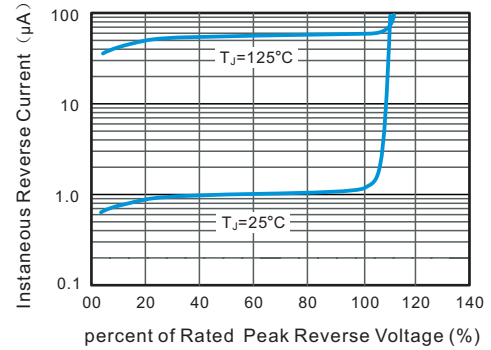

Fig.3 Typical Forward Characteristic

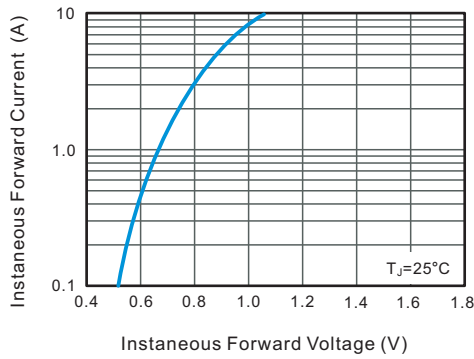

Fig.4 Typical Junction Capacitance

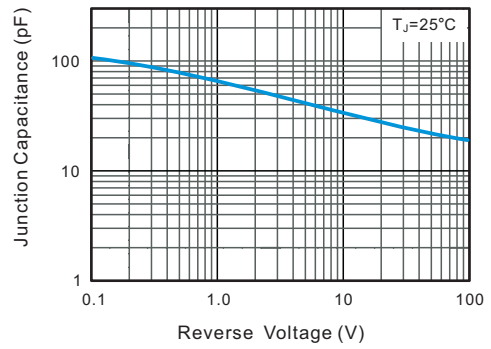
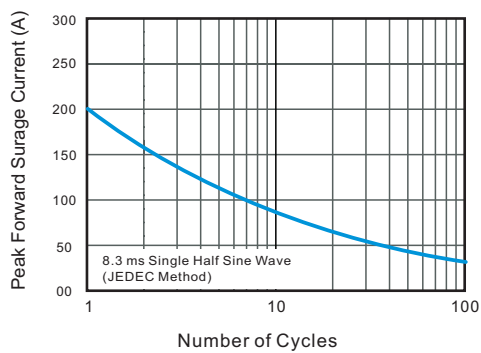
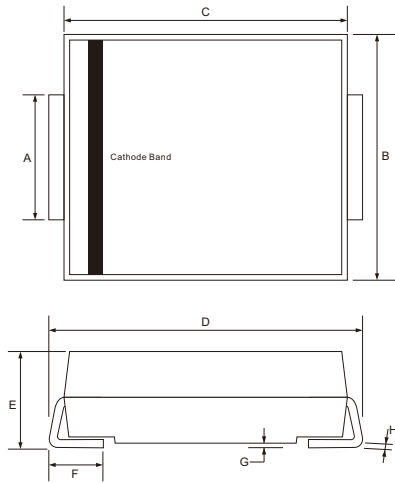

Fig.6 Maximum Non-Repetitive Peak Forward Surge Current



SMC Package Outline



Unit: mm

SYMBOL	DIMENSIONS	
	MIN.	MAX.
A	2.75	3.27
B	5.59	6.22
C	6.50	7.11
D	7.60	8.13
E	1.99	2.80
F	0.76	1.60
G	0.05	0.31
H	0.10	0.31

SMC Suggested Pad Layout

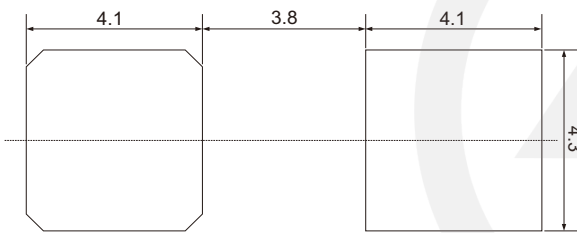

Note:

1. Controlling dimension: in millimeters.
2. General tolerance: $\pm 0.05\text{mm}$
3. The pad layout is for reference purpose only.

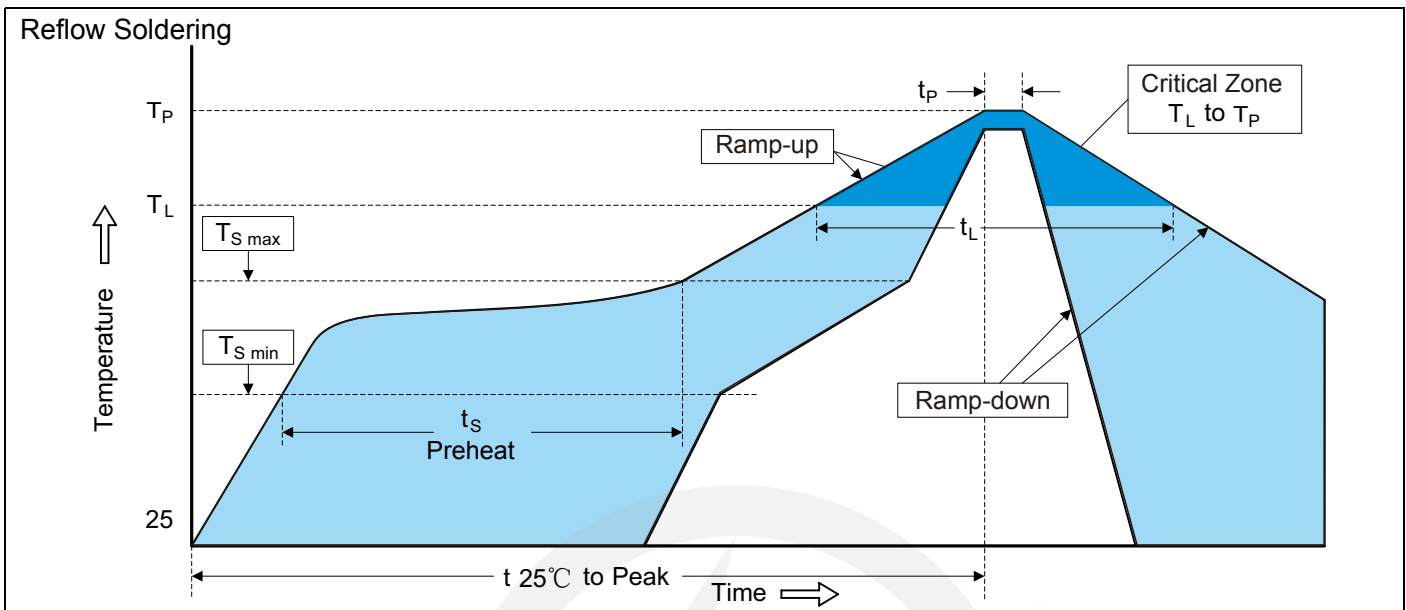
Recommended Soldering Conditions

Recommended Conditions

Profile Feature	Pb-Free Assembly
Average ramp-up rate (T _L to T _P)	3°C/second max.
Preheat -Temperature Min (T _{S min}) -Temperature Max (T _{S max}) -Time (min to max) (t _s)	150°C 200°C 60-180 seconds
T _{S max} to T _L -Ramp-up Rate	3°C/second max.
Time maintained above: -Temperature (T _L) -Time (t _L)	217°C 60-150 seconds
Peak Temperature (T _P)	260°C
Time within 5°C of actual Peak Temperature (t _P)	20-40 seconds
Ramp-down Rate	6°C/second max.
Time 25°C to Peak Temperature	8 minutes max.

Packaging

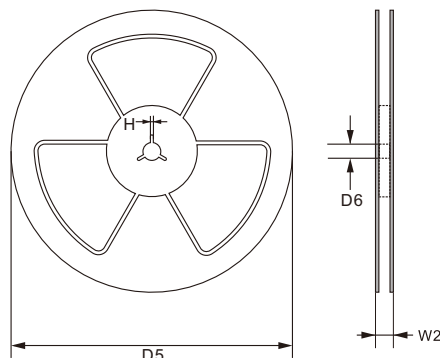
13" Reel



D5 Φ330.0±2.0

D6 Φ13.5±0.5

H 2.5±1.0

W2 16.0±2.0

Quantity: 3000PCS